

10/17/2023 12:07 PM

DRUTEX S.A.

IGLO ENERGY CLASSIC TILT & TURN WINDOW (HVHZ)(IMPACT)

GENERAL NOTES:

- THE PRODUCT SHOWN HEREIN IS DESIGNED AND MANUFACTURED TO COMPLY WITH THE CURRENT EDITION FLORIDA BUILDING CODE (FBC), INCLUDING HVHZ AND HAS BEEN EVALUATED ACCORDING TO THE FOLLOWING:
 - TAS 201-94
 - TAS 202-94
 - TAS 203-94
 - AAMA/WDMA/CSA 101/I.S.2/A440-17
 - ASTM E1886-13a
 - ASTM E1996-17
- ADEQUACY OF THE EXISTING STRUCTURAL CONCRETE/MASONRY, 2X FRAMING, AND METAL FRAMING AS A MAIN WIND FORCE RESISTING SYSTEM CAPABLE OF WITHSTANDING AND TRANSFERRING APPLIED PRODUCT LOADS TO THE FOUNDATION IS THE RESPONSIBILITY OF THE ENGINEER OR ARCHITECT OF RECORD FOR THE PROJECT OF INSTALLATION.
- 1X AND 2X BUCKS (WHEN USED) SHALL BE DESIGNED AND ANCHORED TO PROPERLY TRANSFER ALL LOADS TO THE STRUCTURE. BUCK DESIGN AND INSTALLATION IS THE RESPONSIBILITY OF THE ENGINEER OR ARCHITECT OF RECORD FOR THE PROJECT OF INSTALLATION.
- INSTALL INDIVIDUAL INSTALLATION ANCHORS WITHIN A TOLERANCE OF ±1/4 INCH OF THE DEPICTED LOCATION IN THE ANCHOR LAYOUT DETAIL (I.E., WITHOUT CONSIDERATION OF TOLERANCES). TOLERANCES ARE NOT CUMULATIVE FROM ONE INSTALLATION ANCHOR TO THE NEXT.
- THE INSTALLATION DETAILS DESCRIBED HEREIN ARE GENERIC AND MAY NOT REFLECT ACTUAL CONDITIONS FOR A SPECIFIC SITE. IF SITE CONDITIONS CAUSE INSTALLATION TO DEVIATE FROM THE REQUIREMENTS DETAILED HEREIN, A LICENSED ENGINEER OR ARCHITECT SHALL PREPARE SITE SPECIFIC DOCUMENTS FOR USE WITH THIS DOCUMENT.
- APPROVED IMPACT PROTECTIVE SYSTEM **IS NOT REQUIRED** ON THIS PRODUCT IN AREAS REQUIRING IMPACT RESISTANCE.
- WINDOW FRAME MATERIAL: uPVC
- GLASS MEETS THE REQUIREMENTS OF ASTM E1300 GLASS CHARTS. SEE SHEET 1 FOR GLAZING DETAILS.
- CUSTOM SIZES AVAILABLE UPON REQUEST. CUSTOM DESIGN PRESSURE WILL BE ASSIGNED EQUAL TO NEXT LARGER STANDARD SIZE.

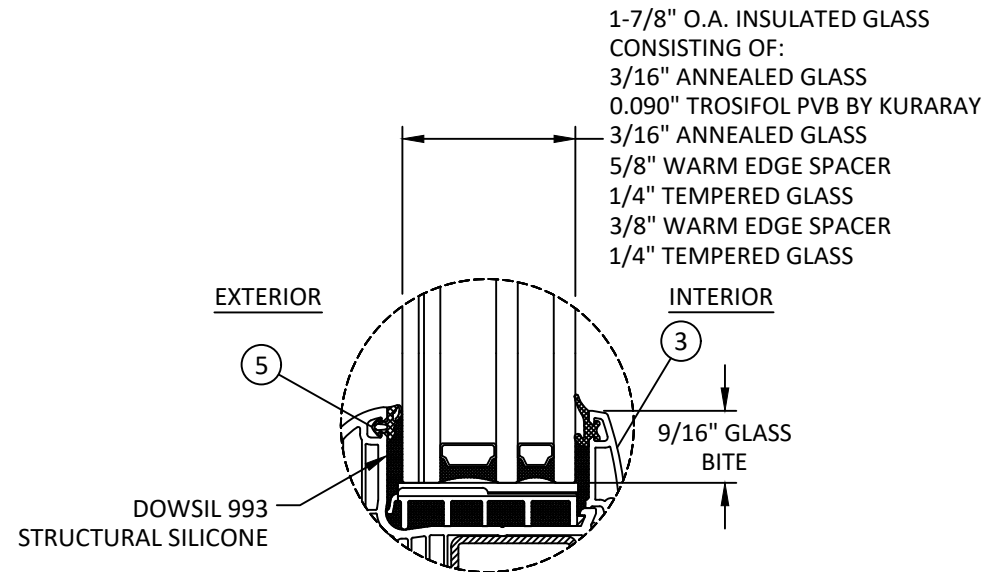

GLAZING DETAIL 1

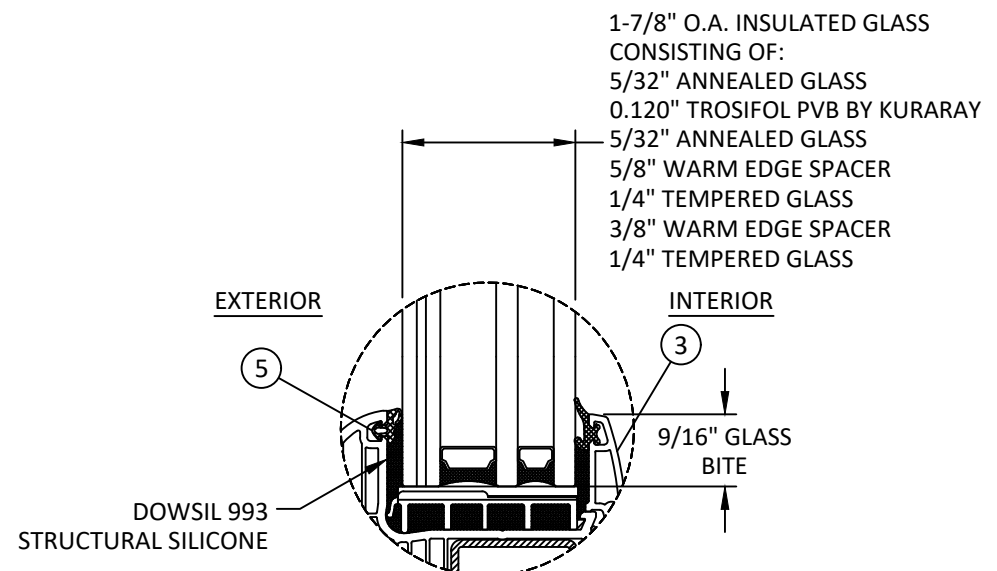

GLAZING DETAIL 2

- GLAZING NOTES:**
- GLASS TYPE COMPLIES WITH ASTM E1300 REQUIREMENTS. PER THE FBC TEMPER AND SAFETY GLAZING REQUIREMENTS SHALL BE REVIEWED ON A SITE SPECIFIC BASIS.
 - SETTING BLOCK DUROMETER HARDNESS OF 70-90 (SHORE A) AS REFERENCED IN FBC CHAPTER 24.
 - SETTING BLOCKS TO BE LOCATED AT 1/4 SPAN LENGTH FOR GLASS WIDER THAN 36" AS PER FBC CHAPTER 24.
 - D.L.O. AND DESIGN PRESSURES MAY NOT EXCEED MAX VALUES SHOWN HEREIN.

1-7/8" O.A. INSULATED GLASS
 CONSISTING OF:
 3/16" ANNEALED GLASS
 0.090" TROSIFOL PVB BY KURARAY
 3/16" ANNEALED GLASS
 5/8" WARM EDGE SPACER
 1/4" TEMPERED GLASS
 3/8" WARM EDGE SPACER
 1/4" TEMPERED GLASS

1-7/8" O.A. INSULATED GLASS
 CONSISTING OF:
 5/32" ANNEALED GLASS
 0.120" TROSIFOL PVB BY KURARAY
 5/32" ANNEALED GLASS
 5/8" WARM EDGE SPACER
 1/4" TEMPERED GLASS
 3/8" WARM EDGE SPACER
 1/4" TEMPERED GLASS

TABLE OF CONTENTS	
SHEET	SHEET DESCRIPTION
1	GENERAL NOTES AND GLAZING DETAILS
2	ELEVATION AND DESIGN PRESSURE TABLE
3	ANCHOR LAYOUTS
4	VERTICAL SECTIONS
5	HORIZONTAL SECTIONS
6	ANCHOR DETAILS AND INSTALLATION NOTES
7	ANCHOR DETAILS CONTINUED
8	BILL OF MATERIALS & COMPONENTS

DESIGN PRESSURE RATING (PSF)				
CONFIGURATION	WIDTH (IN.)	HEIGHT (IN.)	DESIGN PRESSURE	MISSILE IMPACT RATING
X	SEE TABLE ON SHEET 2			LARGE & SMALL MISSILE IMPACT



LEBORSKA 31, 77-100
 BYTOW, POLAND
 PH: +48-59-822-9101 FX: +48-59-822-9103

TITLE: IGLO ENERGY CLASSIC TILT & TURN WINDOW (HVHZ)(IMPACT)
 GENERAL NOTES & GLAZING DETAILS

PREPARED BY: BUILDING DROPS, INC.
 1900 NE MIAMI COURT., STE. 2-15
 MIAMI, FL 33132
 PH: (954) 399-8478
 FAX: (954) 744-4738
 WEB: www.buildingdrops.com



REMARKS	BY	DATE
8TH FBC CODE CHANGE	FB	10.17.23

THE INSTALLATION DETAILS DESCRIBED HEREIN ARE GENERIC AND MAY NOT REFLECT ACTUAL CONDITIONS FOR A SPECIFIC SITE. IF SITE CONDITIONS CAUSE INSTALLATION TO DEVIATE FROM THE REQUIREMENTS DETAILED HEREIN, A LICENSED ENGINEER OR ARCHITECT SHALL PREPARE SITE SPECIFIC DOCUMENTS FOR USE WITH THIS DOCUMENT.

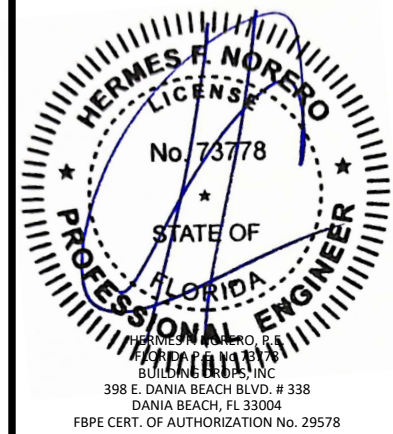

FL #: **FL41836**

DATE: **12.12.2022**

DWG. BY: **SH** | CHK. BY: **HFN**

SCALE: **NTS**

DWG. #: **DRU014**

SHEET: **1** OF 8

s:\projects\drutex_s.a\cc-23-0959 - fbc submittal - 2023 code change\dwgs\141836 - tilt & turn\dr014 - fbc 2023.dwg

10/17/2023 12:07 PM

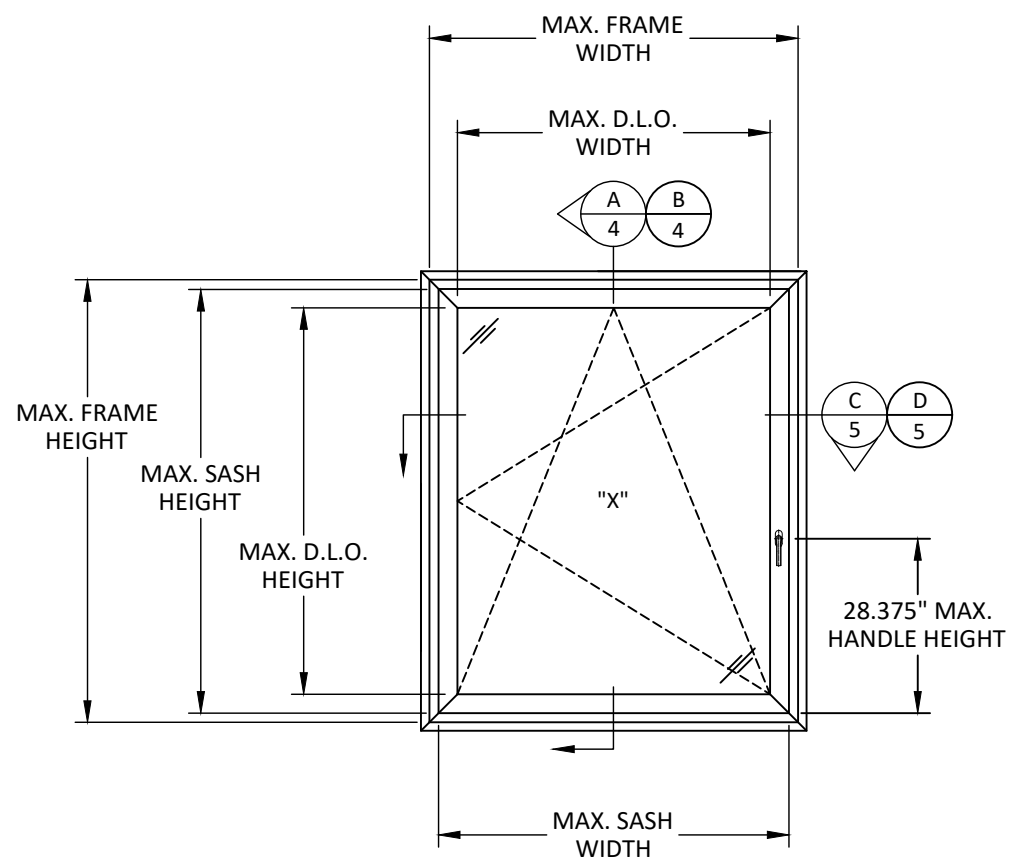

ELEVATION

SASH HEIGHT = FRAME HEIGHT - 3.0"
 SASH WIDTH = FRAME WIDTH - 3.0"
 D.L.O. HEIGHT = FRAME HEIGHT - 9.75"
 D.L.O. WIDTH = FRAME WIDTH - 9.75"

DESIGN PRESSURE TABLE (PSF)			
NOMINAL DIMS.		GLASS TYPE 1	GLASS TYPE 2
FRAME WIDTH (in.)	FRAME HEIGHT (in.)	EXT. (+) INT. (-)	EXT. (+) INT. (-)
36.0	54.0	55.0	70.0
42.0		55.0	70.0
48.0		55.0	70.0
54.0	60.0	55.0	70.0
36.0		55.0	70.0
42.0		55.0	70.0
48.0	66.0	55.0	70.0
54.0		55.0	70.0
60.0		55.0	70.0
36.0	72.0	55.0	70.0
42.0		55.0	70.0
48.0		55.0	70.0
54.0	78.0	55.0	70.0
60.0		55.0	70.0
36.0		54.5	69.4
42.0	84.0	55.0	70.0
48.0		55.0	70.0
54.0		55.0	70.0
36.0	90.0	55.0	70.0
42.0		55.0	70.0
48.0		54.7	69.6
36.0	96.0	55.0	70.0
42.0		55.0	70.0
36.0		55.0	70.0
42.0	102.0	55.0	70.0
36.0		55.0	70.0
36.0	108.0	55.0	70.0
36.0	114.0	55.0	70.0
36.0	120.0	55.0	70.0

NOTE: ALL PRESSURES MEET WATER INFILTRATION REQUIREMENTS.



LEBORSKA 31, 77-100
 BYTOW, POLAND
 PH: +48-59-822-9101 FX: +48-59-822-9103

TITLE: IGLU ENERGY CLASSIC
 TILT & TURN WINDOW
 (HVHZ)/(IMPACT)
 ELEVATION &
 DESIGN PRESSURE TABLE

PREPARED BY:
BUILDING DROPS, INC.
 1900 NE MIAMI COURT., STE. 2-15
 MIAMI, FL 33132
 PH: (954)399-8478
 FAX: (954)744-4738
 WEB: www.buildingdrops.com



REMARKS	BY	DATE
8TH FBC CODE CHANGE	FB	10.17.23

THE INSTALLATION DETAILS DESCRIBED HEREIN ARE GENERIC AND MAY NOT REFLECT ACTUAL CONDITIONS FOR A SPECIFIC SITE. IF SITE CONDITIONS CAUSE INSTALLATION TO DEVIATE FROM THE REQUIREMENTS DETAILED HEREIN, A LICENSED ENGINEER OR ARCHITECT SHALL PREPARE SITE SPECIFIC DOCUMENTS FOR USE WITH THIS DOCUMENT.

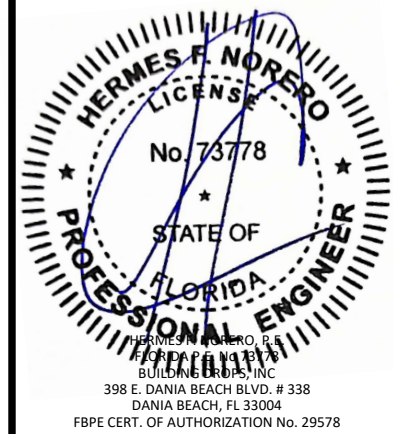

FL #: **FL41836**

DATE: **12.12.2022**

DWG. BY: **SH** CHK. BY: **HFN**

SCALE: **NTS**

DWG. #: **DRU014**

SHEET: **2**
 OF 8

s:\projects\drutex, s.a\cc-23-0959 - fbc submittal - 2023 code change\dwgs\141836 - tilt & turn\dr014 - fbc 2023.dwg

10/17/2023 12:07 PM

s:\projects\drutex, s.a\cc-23-0959 - fbc submittal - 2023 code change\dwgs\141836 - tilt & turn\dr014 - fbc 2023.dwg

INSTALLATION LEGEND:
 — THROUGH FRAME/NAIL-FIN
 ▬ STRAP

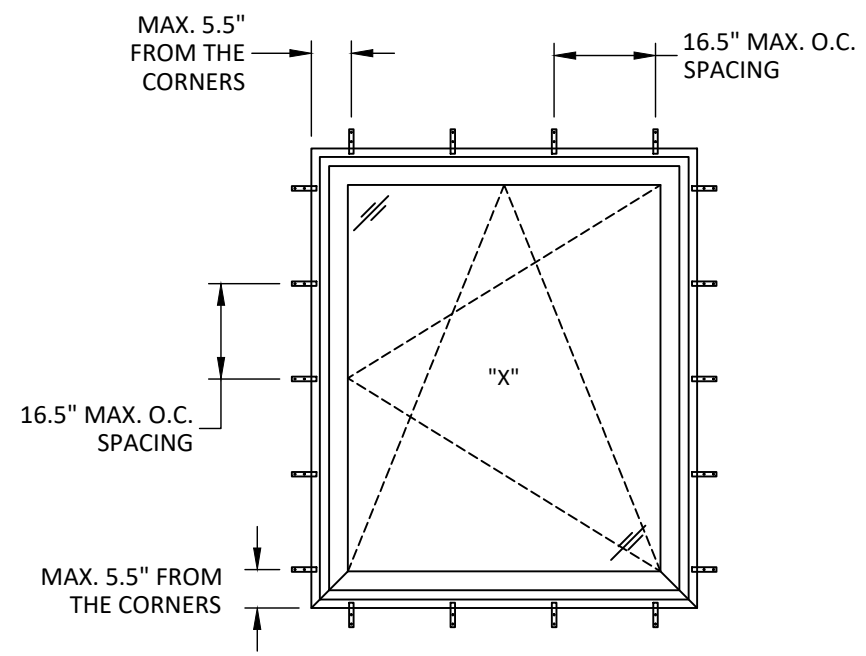

ANCHOR LAYOUT
STRAP INSTALLATION

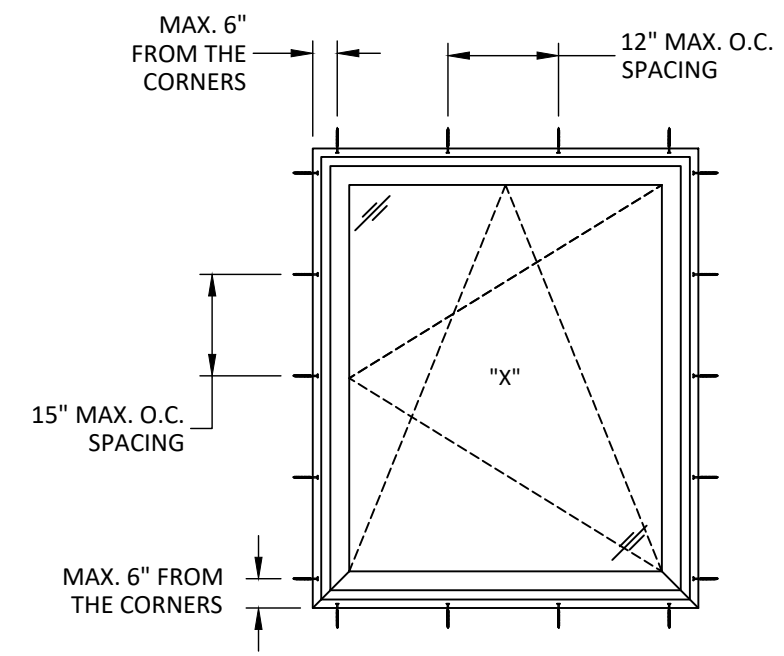

ANCHOR LAYOUT
THROUGH FRAME INSTALLATION

NOTE: TWO (2) INSTALLATION ANCHORS PER STRAP LOCATION.

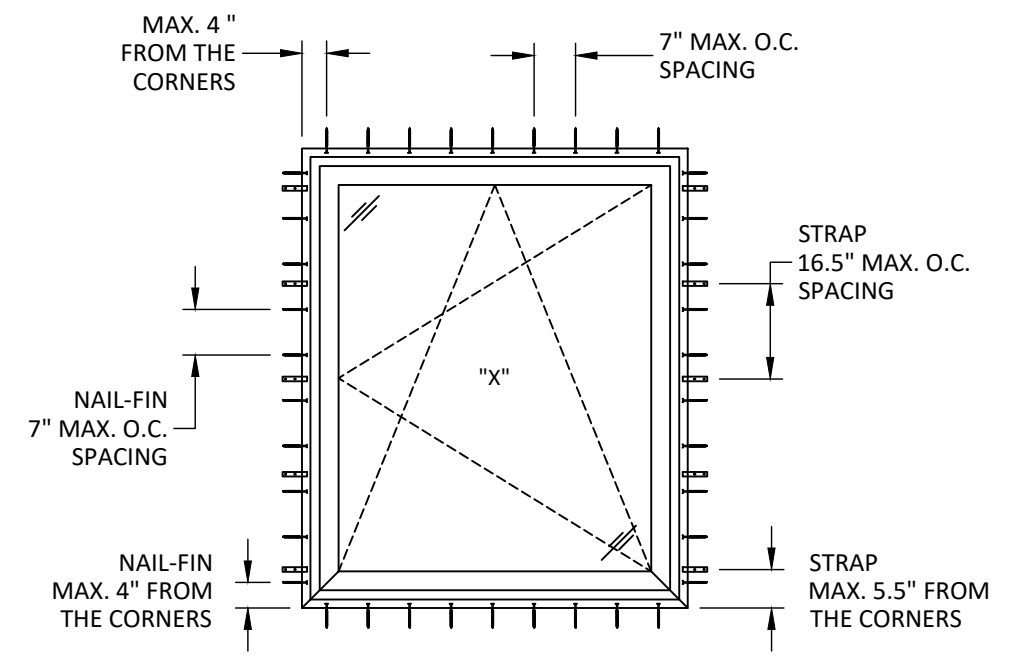

ANCHOR LAYOUT
NAIL-FIN & STRAP INSTALLATION

NOTE: WHEN NAIL-FIN INSTALLATION IS USED, STRAPS MUST BE USED AT THE JAMBS.



LEBORSKA 31, 77-100
 BYTOW, POLAND
 PH: +48-59-822-9101 FX: +48-59-822-9103

TITLE: IGLO ENERGY CLASSIC TILT & TURN WINDOW (HVHZ)/(IMPACT) ANCHOR LAYOUTS
 PREPARED BY: BUILDING DROPS, INC.
 1900 NE MIAMI COURT., STE. 2-15
 MIAMI, FL 33132
 PH: (954)399-8478
 FAX: (954)744-4738
 WEB: www.buildingdrops.com

REMARKS	BY	DATE
8TH FBC CODE CHANGE	FB	10.17.23

THE INSTALLATION DETAILS DESCRIBED HEREIN ARE GENERIC AND MAY NOT REFLECT ACTUAL CONDITIONS FOR A SPECIFIC SITE. IF SITE CONDITIONS CAUSE INSTALLATION TO DEVIATE FROM THE REQUIREMENTS DETAILED HEREIN, A LICENSED ENGINEER OR ARCHITECT SHALL PREPARE SITE SPECIFIC DOCUMENTS FOR USE WITH THIS DOCUMENT.

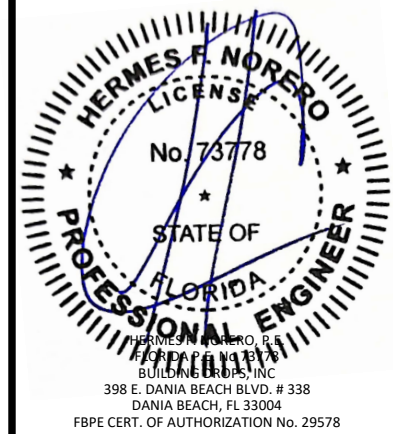

FL #:	FL41836
DATE:	12.12.2022
DWG. BY:	SH
CHK. BY:	HFN
SCALE:	NTS
DWG. #:	DRU014
SHEET:	3
	OF 8

10/17/2023 12:07 PM
s:\projects\drutex, s.a\cc-23-0959 - fbc submittal - 2023 code change\dwgs\141836 - tilt & turn\dr014 - fbc 2023.dwg

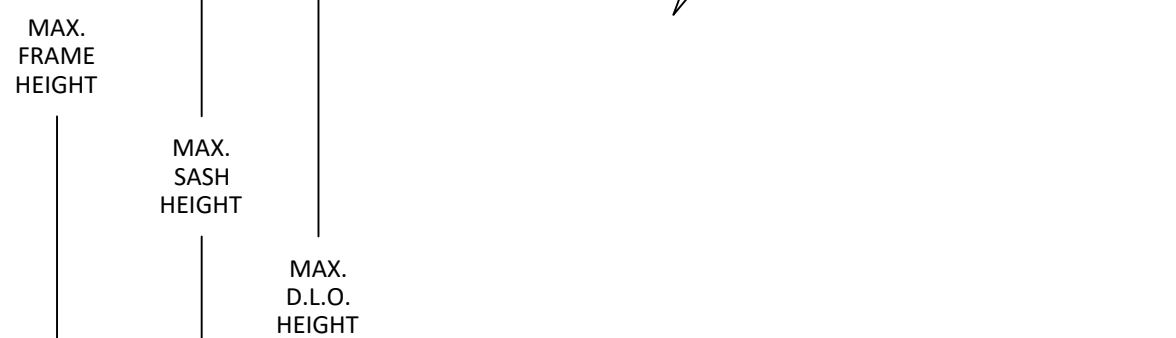
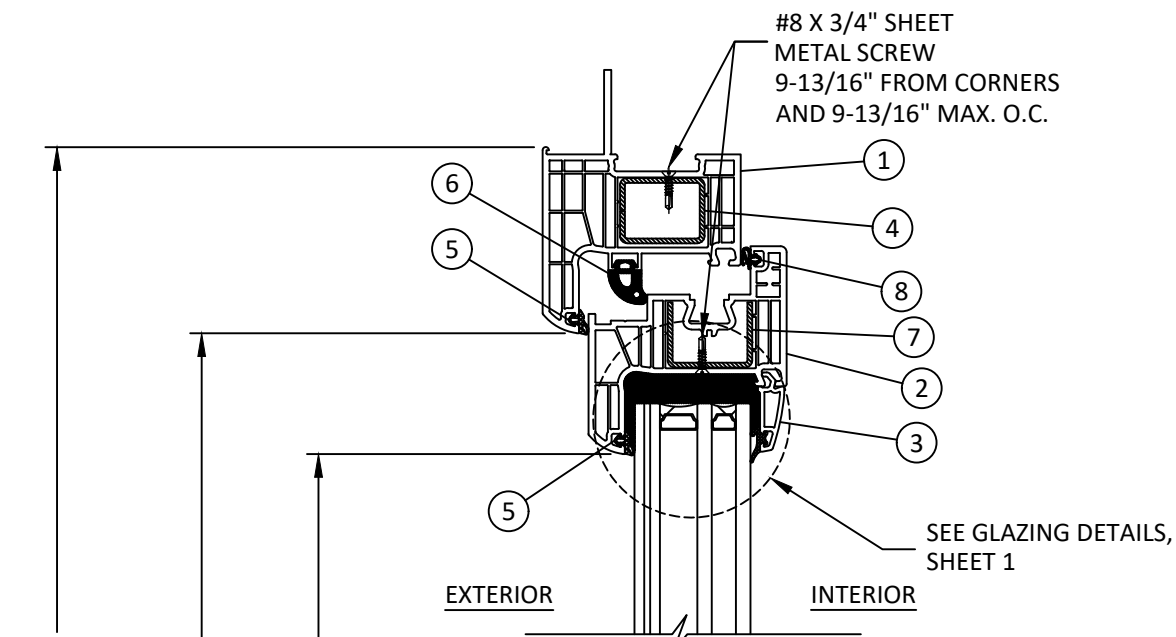

A
4 VERTICAL SECTION
FIN SECTION DETAIL

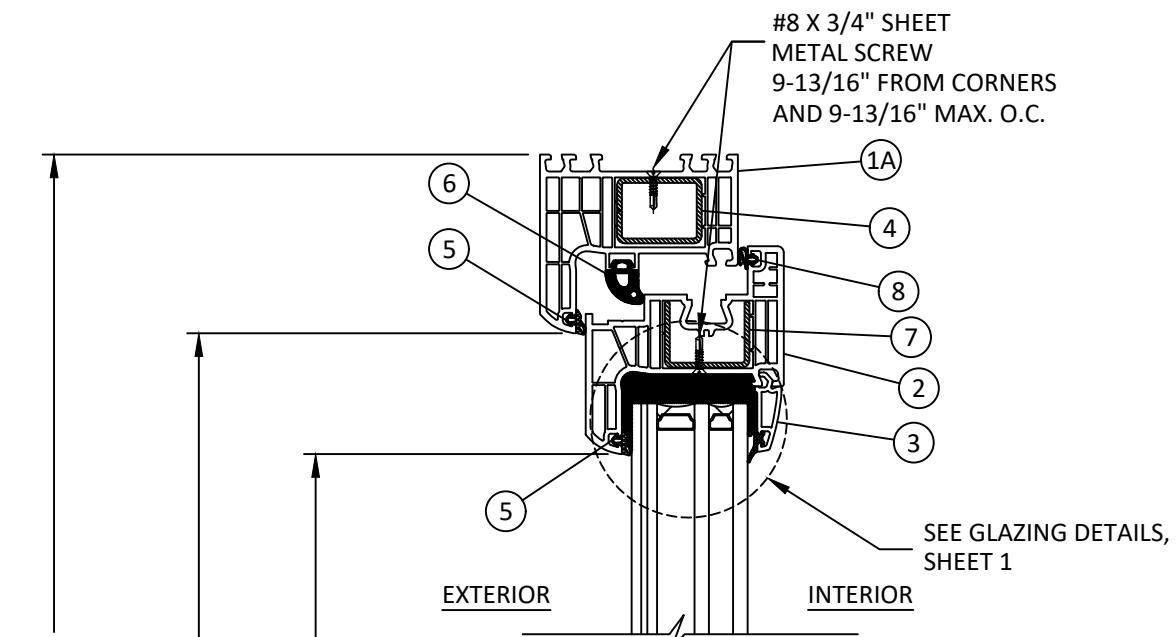

B
4 VERTICAL SECTION
FINLESS SECTION DETAIL



LEBORSKA 31, 77-100
BYTOW, POLAND
PH: +48-59-822-9101 FX: +48-59-822-9103

TITLE: IGLU ENERGY CLASSIC
TILT & TURN WINDOW
(HVHZ)/(IMPACT)
VERTICAL SECTIONS

PREPARED BY:
BUILDING DROPS, INC.
1900 NE MIAMI COURT., STE. 2-15
MIAMI, FL 33132
PH: (954) 399-8478
FAX: (954) 744-4738
WEB: www.buildingdrops.com



REMARKS	BY	DATE
8TH FBC CODE CHANGE	FB	10.17.23

THE INSTALLATION DETAILS DESCRIBED HEREIN ARE GENERIC AND MAY NOT REFLECT ACTUAL CONDITIONS FOR A SPECIFIC SITE. IF SITE CONDITIONS CAUSE INSTALLATION TO DEVIATE FROM THE REQUIREMENTS DETAILED HEREIN, A LICENSED ENGINEER OR ARCHITECT SHALL PREPARE SITE SPECIFIC DOCUMENTS FOR USE WITH THIS DOCUMENT.

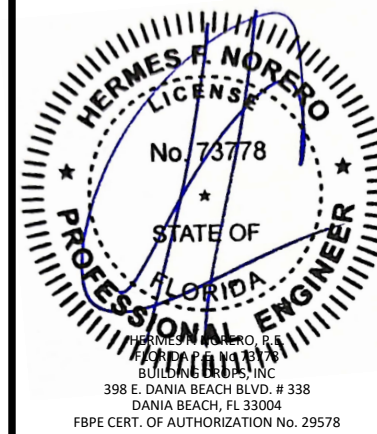

FL #:	FL41836
DATE:	12.12.2022
DWG. BY:	SH
CHK. BY:	HFN
SCALE:	NTS
DWG. #:	DRU014
SHEET:	4
	OF 8

10/17/2023 12:07 PM

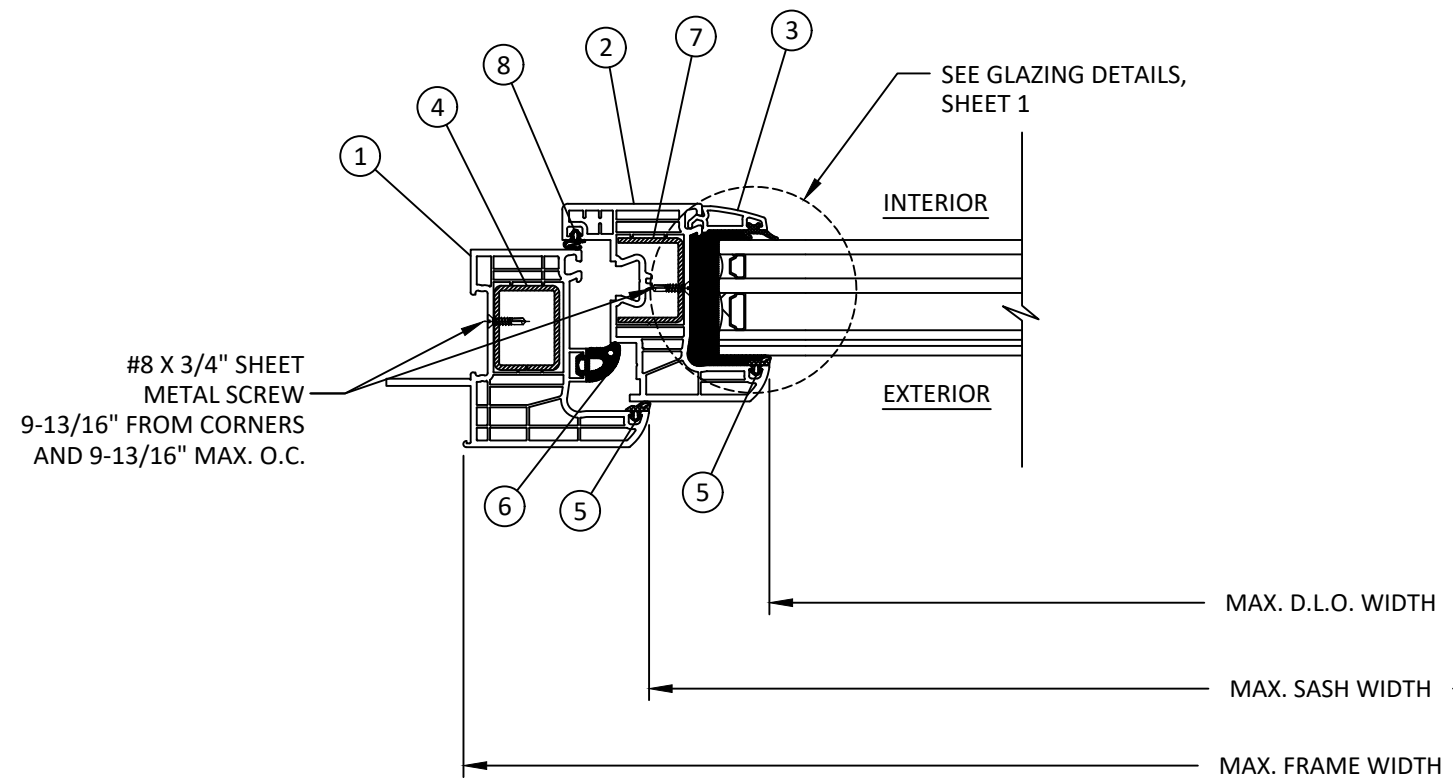

C HORIZONTAL SECTION
5 FIN SECTION DETAIL

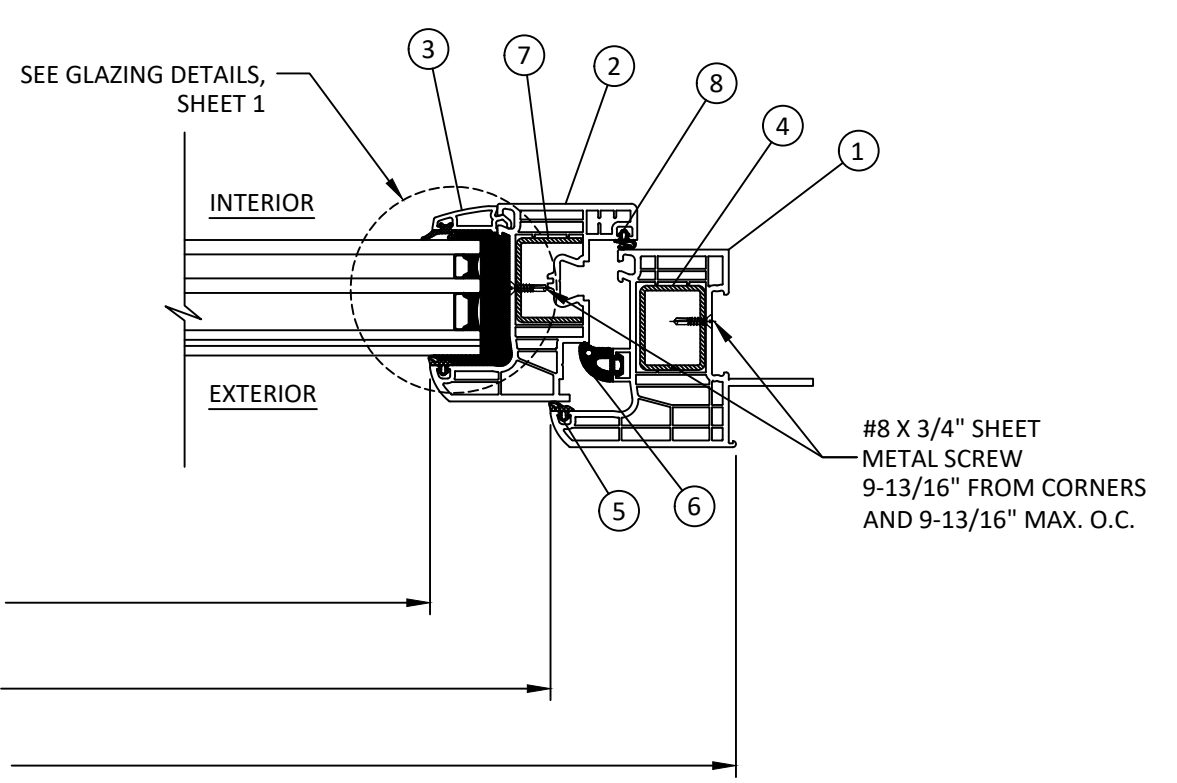

D HORIZONTAL SECTION
5 FINLESS SECTION DETAIL

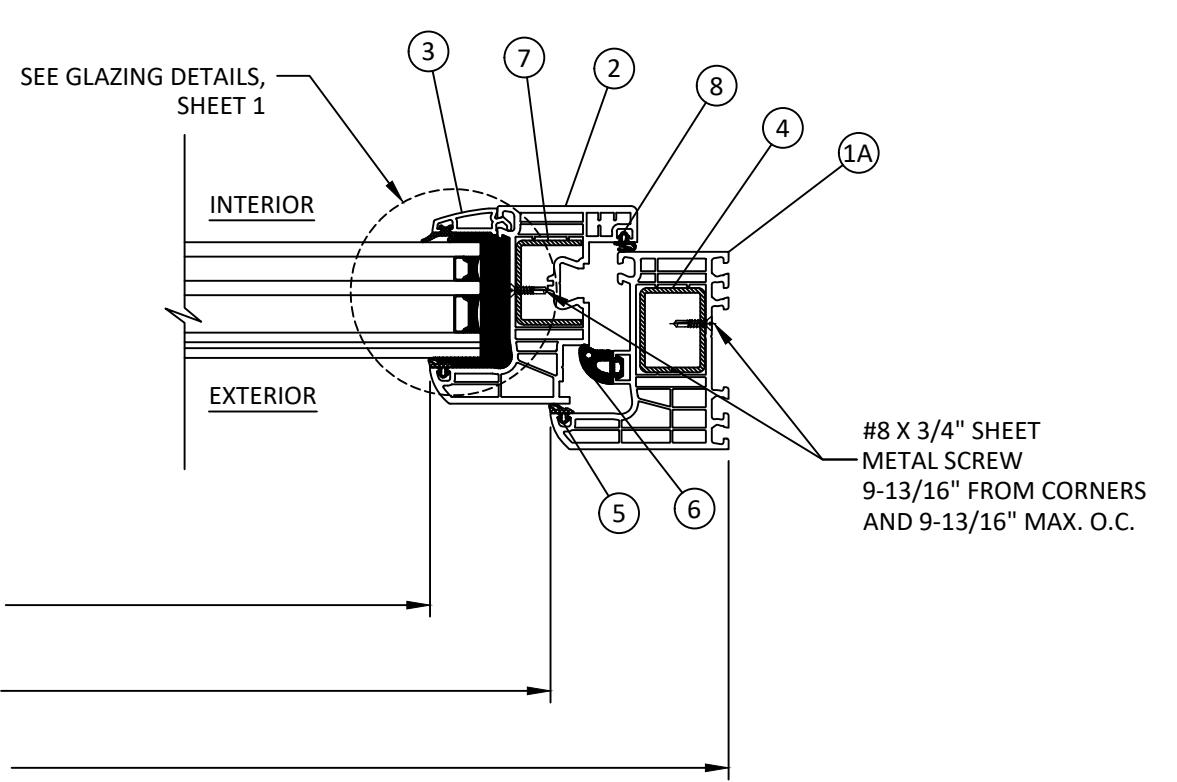
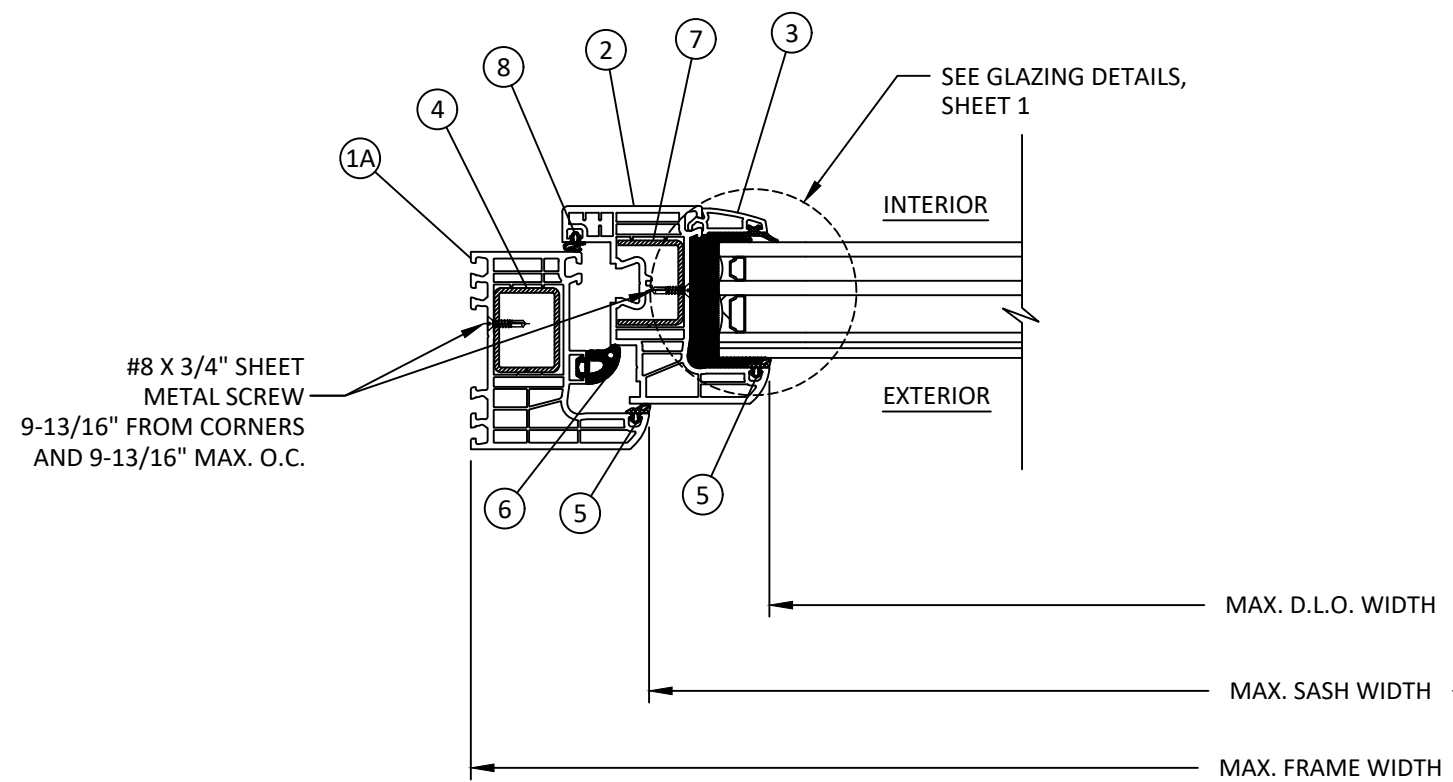

LEBORSKA 31, 77-100
BYTOW, POLAND
PH: +48-59-822-9101 FX: +48-59-822-9103

TITLE: IGLU ENERGY CLASSIC
TILT & TURN WINDOW
(HVHZ)/(IMPACT)
HORIZONTAL SECTIONS

PREPARED BY: BUILDING DROPS, INC.
1900 NE MIAMI COURT., STE. 2-15
MIAMI, FL 33132
PH: (954) 399-8478
FAX: (954) 744-4738
WEB: www.buildingdrops.com

REMARKS	BY	DATE
8TH FBC CODE CHANGE	FB	10.17.23

THE INSTALLATION DETAILS DESCRIBED HEREIN ARE GENERIC AND MAY NOT REFLECT ACTUAL CONDITIONS FOR A SPECIFIC SITE. IF SITE CONDITIONS CAUSE INSTALLATION TO DEVIATE FROM THE REQUIREMENTS DETAILED HEREIN, A LICENSED ENGINEER OR ARCHITECT SHALL PREPARE SITE SPECIFIC DOCUMENTS FOR USE WITH THIS DOCUMENT.

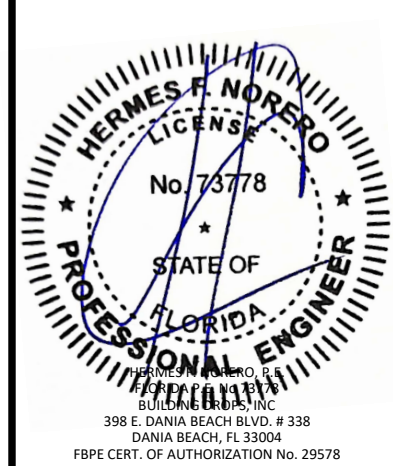

FL #: **FL41836**

DATE: **12.12.2022**

DWG. BY: **SH** | CHK. BY: **HFN**

SCALE: **NTS**

DWG. #: **DRU014**

SHEET: **5**
OF 8

s:\projects\drutex, s.a\cc-23-0959 - fbc submittal - 2023 code change\dwgs\141836 - tilt & turn\dr014 - fbc 2023.dwg

10/17/2023 12:07 PM

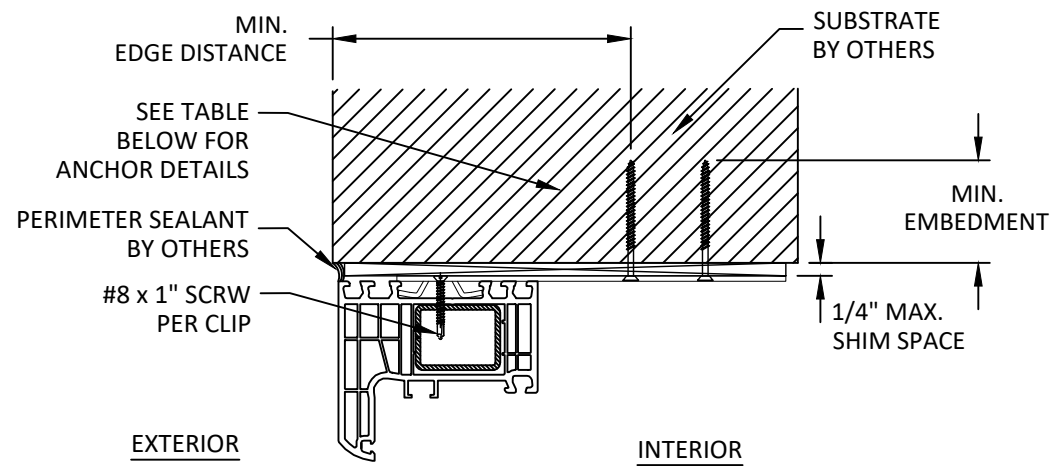

A
6 VERTICAL SECTION
HEAD - STRAP

NOTE: SILL & JAMB SIMILAR

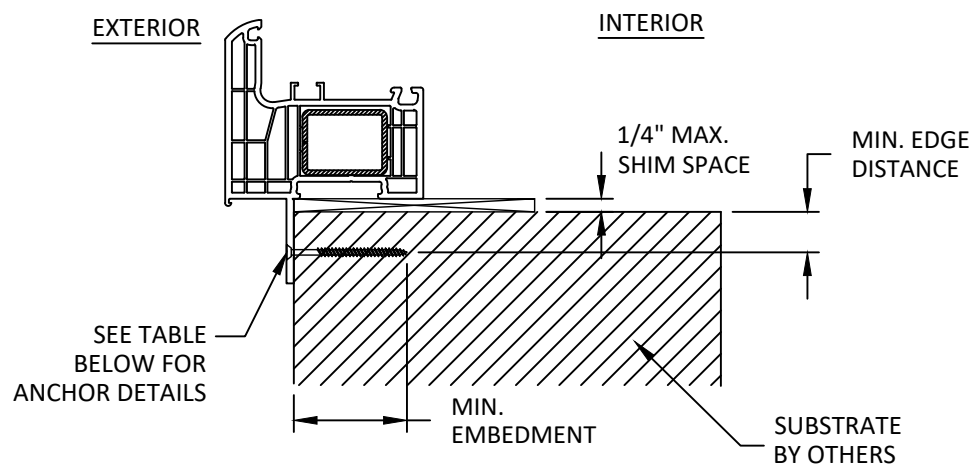

B
6 VERTICAL SECTION
SILL - NAIL-FIN

NOTE: HEAD & JAMB SIMILAR

INSTALLATION NOTES:

- ONE (1) INSTALLATION ANCHOR IS REQUIRED AT EACH ANCHOR LOCATION SHOWN, UNLESS OTHERWISE STATED ON SHEET 3.
- INSTALL INDIVIDUAL INSTALLATION ANCHORS WITHIN A TOLERANCE OF ± 1.000 INCH THE DEPICTED LOCATION & SPACING IN THE ANCHOR LAYOUT DETAILS (I.E., WITHOUT CONSIDERATION OF TOLERANCES). TOLERANCES ARE NOT CUMULATIVE FROM ONE INSTALLATION ANCHOR TO THE NEXT.
- SHIM AS REQUIRED AT EACH INSTALLATION ANCHOR WITH LOAD BEARING SHIM(S). MAXIMUM ALLOWABLE SHIM STACK TO BE 1/4 INCH. SHIM WHERE SPACE OF 1/16 INCH OR GREATER OCCURS. SHIM(S) SHALL BE CONSTRUCTED OF HIGH DENSITY PLASTIC OR BETTER.
- MINIMUM EMBEDMENT AND EDGE DISTANCE EXCLUDE WALL FINISHES, INCLUDING BUT NOT LIMITED TO STUCCO, FOAM, BRICK VENEER, AND SIDING.
- INSTALLATION ANCHORS AND ASSOCIATED HARDWARE MUST BE MADE OF CORROSION RESISTANT MATERIAL OR HAVE A CORROSION RESISTANT COATING.
- FOR MASONRY OR CONCRETE OPENINGS, A 1X WOOD BUCK MAY BE USED (OPTIONAL) AS LONG AS THE MINIMUM EMBEDMENT AND EDGE DISTANCE REQUIREMENTS ARE STILL MET WITHIN THE CORRESPONDING HOST SUBSTRATE. SEE GENERAL NOTE #3 ON SHEET 1 FOR MORE INFORMATION.
- FOR HOLLOW BLOCK AND GROUT FILLED BLOCK, DO NOT INSTALL INSTALLATION ANCHORS INTO MORTAR JOINTS. EDGE DISTANCE IS MEASURED FROM FREE EDGE OF BLOCK OR EDGE OF MORTAR JOINT INTO FACE SHELL OF BLOCK.
- INSTALLATION ANCHORS SHALL BE INSTALLED IN ACCORDANCE WITH ANCHOR MANUFACTURER'S INSTALLATION INSTRUCTIONS, AND ANCHORS SHALL NOT BE USED IN SUBSTRATES WITH STRENGTHS LESS THAN THE MINIMUM STRENGTH SPECIFIED BY THE ANCHOR MANUFACTURER.

ANCHOR SCHEDULE					
METHOD	SUBSTRATE	ANCHOR SCHEDULE	MIN EMBEDMENT	MIN. EDGE DISTANCE	SPACING
NAIL-FIN	WOOD: MIN. SG = 0.55	#8 WOOD SCREW	1.50"	0.75"	SEE SHEET 3
	METAL: 18 GAUGE STEEL, MIN. Fy = 33KSI ALUMINUM: 1/8" MIN., 6063-T5	#8 SELF-DRILLING SCREW	3 THREADS MIN PENETRATION BEYOND STRUCTURE	0.50"	
	CONCRETE: f _c =3000PSI	3/16" ITW TAPCON	1.25"	2.00"	
	MASONRY: CMU per ASTM C90 MIN. 2000 PSI	3/16" ITW TAPCON	1.00"	2.00"	
STRAP OR THROUGH FRAME	WOOD: MIN. SG = 0.55	#10 WOOD SCREW	1.50"	0.75"	SEE SHEET 3
	METAL: 18 GAUGE STEEL, MIN. Fy = 33KSI ALUMINUM: 1/8" MIN., 6063-T5	#10 SELF-DRILLING SCREW	3 THREADS MIN PENETRATION BEYOND STRUCTURE	0.50"	
	CONCRETE: f _c =3000PSI	3/16" ITW TAPCON	1.25"	2.00"	
	MASONRY: CMU per ASTM C90 MIN. 2000 PSI	3/16" ITW TAPCON	1.00"	2.00"	



LEBORSKA 31, 77-100
BYTOW, POLAND
PH: +48-59-822-9101 FX: +48-59-822-9103

TITLE: IGL0 ENERGY CLASSIC
TILT & TURN WINDOW
(HVHZ)/(IMPACT)
ANCHOR DETAILS &
INSTALLATION NOTES

PREPARED BY:
BUILDING DROPS, INC.
1900 NE MIAMI COURT., STE. 2-15
MIAMI, FL 33132
PH: (954)399-8478
FAX: (954)744-4738
WEB: www.buildingdrops.com



REMARKS	BY	DATE
8TH FBC CODE CHANGE	FB	10.17.23

THE INSTALLATION DETAILS DESCRIBED HEREIN ARE GENERIC AND MAY NOT REFLECT ACTUAL CONDITIONS FOR A SPECIFIC SITE. IF SITE CONDITIONS CAUSE INSTALLATION TO DEVIATE FROM THE REQUIREMENTS DETAILED HEREIN, A LICENSED ENGINEER OR ARCHITECT SHALL PREPARE SITE SPECIFIC DOCUMENTS FOR USE WITH THIS DOCUMENT.

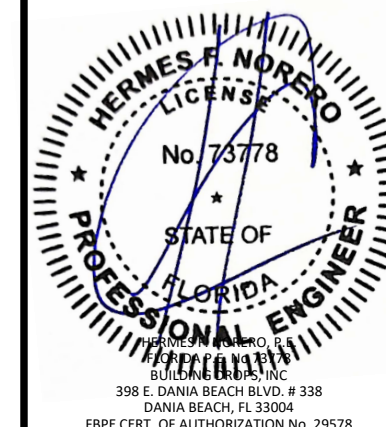

FL #: **FL41836**

DATE: **12.12.2022**

DWG. BY: **SH** CHK. BY: **HFN**

SCALE: **NTS**

DWG. #: **DRU014**

SHEET:

6

OF 8

s:\projects\drutex, s.a\cc-23-0959 - fbc submittal - 2023 code change\dwgs\141836 - tilt & turn\dr014 - fbc 2023.dwg

10/17/2023 12:07 PM
s:\projects\drutex, s.a\cc-23-0959 - fbc submittal - 2023 code change\dwgs\141836 - tilt & turn\dr014 - fbc 2023.dwg

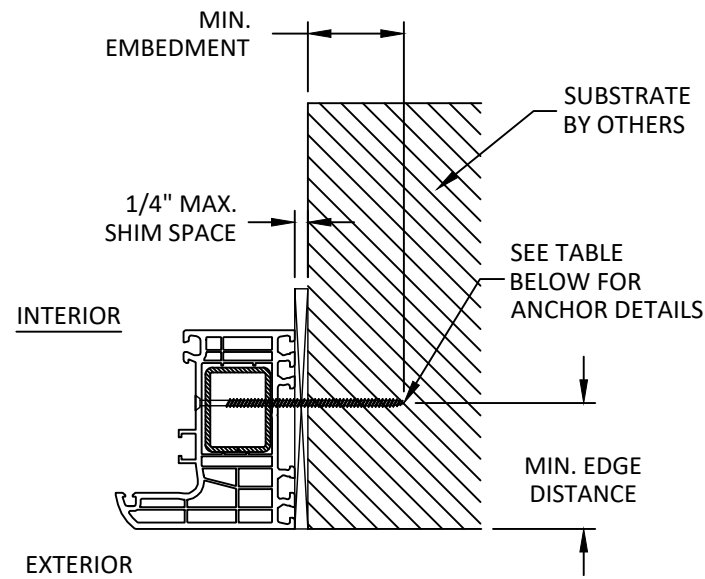

C
7 HORIZONTAL SECTION
JAMB - THROUGH FRAME

NOTE: HEAD & SILL SIMILAR

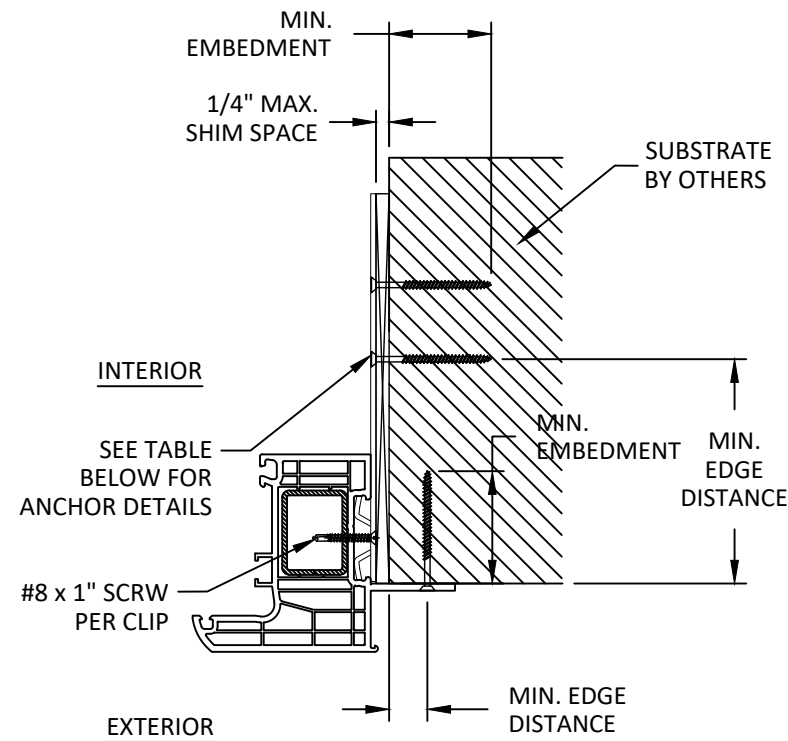

D
7 HORIZONTAL SECTION
JAMB - NAIL-FIN & STRAP



LEBORSKA 31, 77-100
BYTOW, POLAND
PH: +48-59-822-9101 FX: +48-59-822-9103

TITLE: IGLO ENERGY CLASSIC
TILT & TURN WINDOW
(HVHZ)/(IMPACT)
ANCHOR DETAILS
CONTINUED

PREPARED BY:
BUILDING DROPS, INC.
1900 NE MIAMI COURT., STE. 2-15
MIAMI, FL 33132
PH: (954)399-8478
FAX: (954)744-4738
WEB: www.buildingdrops.com



REMARKS	BY	DATE
8TH FBC CODE CHANGE	FB	10.17.23

THE INSTALLATION DETAILS DESCRIBED HEREIN ARE GENERIC AND MAY NOT REFLECT ACTUAL CONDITIONS FOR A SPECIFIC SITE. IF SITE CONDITIONS CAUSE INSTALLATION TO DEVIATE FROM THE REQUIREMENTS DETAILED HEREIN, A LICENSED ENGINEER OR ARCHITECT SHALL PREPARE SITE SPECIFIC DOCUMENTS FOR USE WITH THIS DOCUMENT.

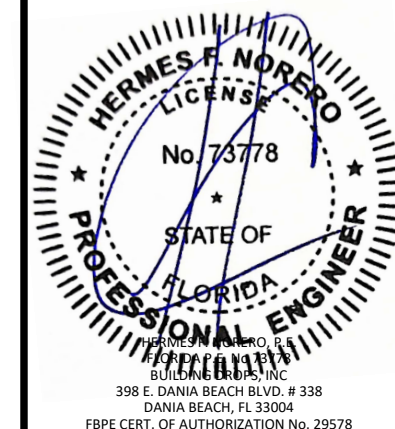

FL #:	FL41836
DATE:	12.12.2022
DWG. BY:	SH
CHK. BY:	HFN
SCALE:	NTS
DWG. #:	DRU014
SHEET:	7

10/17/2023 12:07 PM

BILL OF MATERIALS			
ITEM	PART NO.	DESCRIPTION	MATERIAL
1	70009	FRAME (FIN)	uPVC
1A	70001	FRAME (FINLESS)	uPVC
2	70013	SASH	uPVC
3	70948	GLAZING BEAD	uPVC
4	250030	FRAME REINFORCEMENT	STEEL
5	U-001	GASKET	EPDM
6	U-007	GASKET	EPDM
7	250026	SASH REINFORCEMENT	STEEL
8	U-002	GASKET	EPDM
9	-	DRAIN PLUG	ASA
10	-	MACO HARDWARE	GALVANIZED STEEL
11	-	STRAP	STEEL

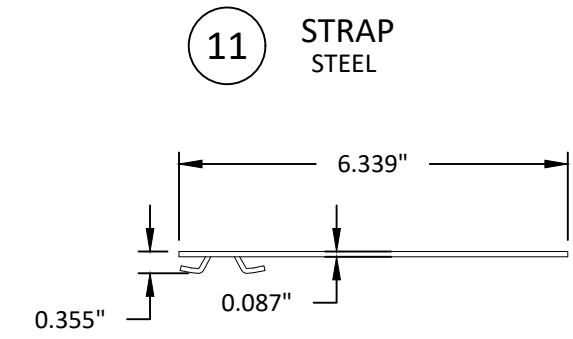
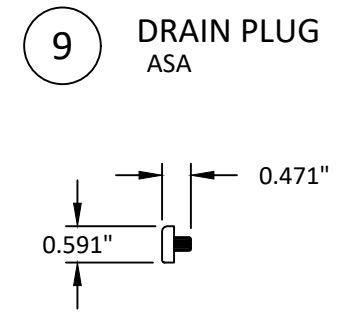
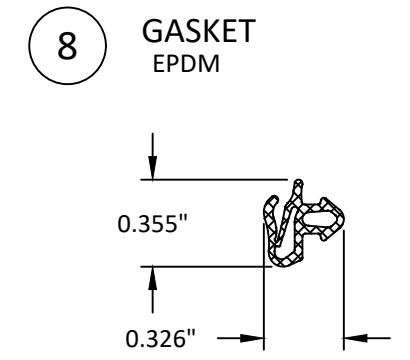
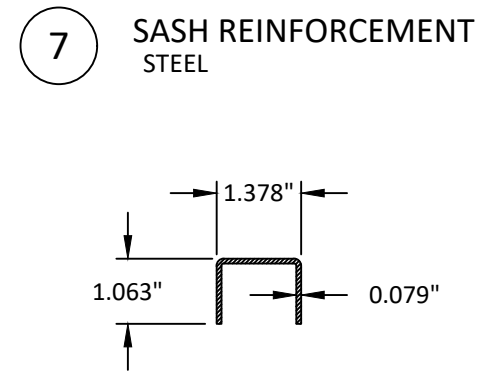
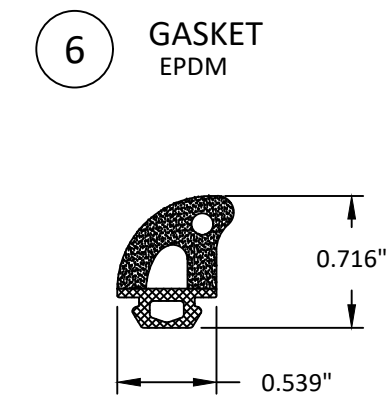
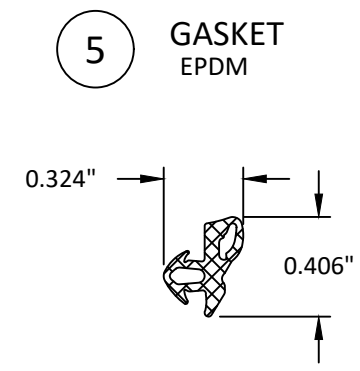
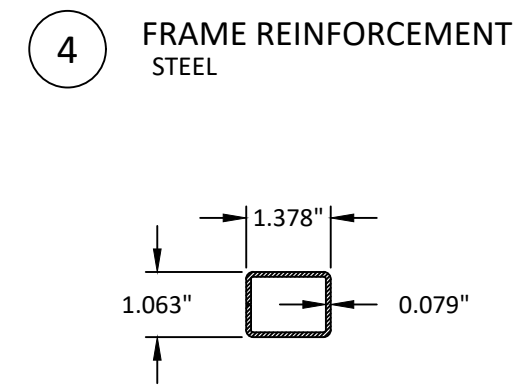
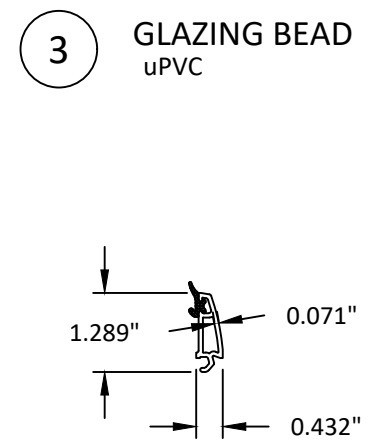
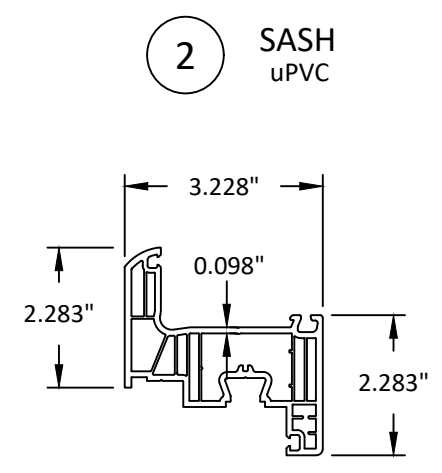
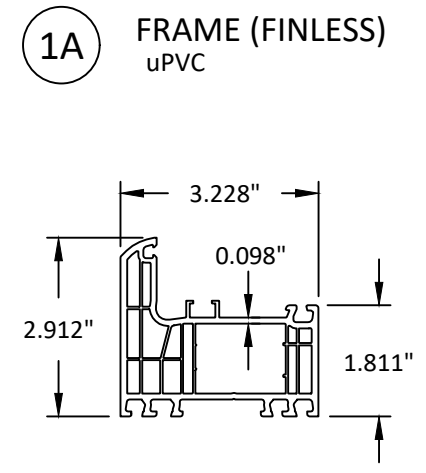
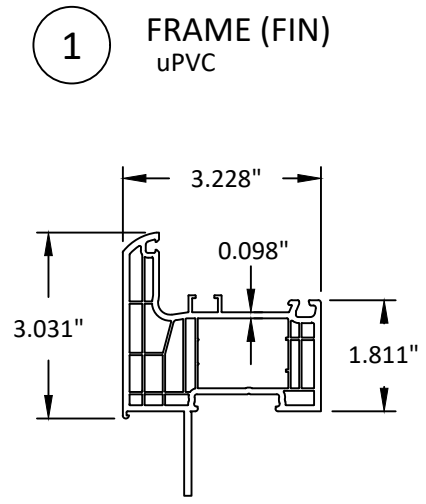

LEBORSKA 31, 77-100
BYTOW, POLAND
PH: +48-59-822-9101 FX: +48-59-822-9103

TITLE: IGLO ENERGY CLASSIC
TILT & TURN WINDOW
(HVHZ)/(IMPACT)
BILL OF MATERIALS
& COMPONENTS

PREPARED BY:
BUILDING DROPS, INC.
1900 NE MIAMI COURT, STE. 2-15
MIAMI, FL 33132
PH: (954) 399-8478
FAX: (954) 744-4738
WEB: www.buildingdrops.com

REMARKS	BY	DATE
8TH FBC CODE CHANGE	FB	10.17.23

THE INSTALLATION DETAILS DESCRIBED HEREIN ARE GENERIC AND MAY NOT REFLECT ACTUAL CONDITIONS FOR A SPECIFIC SITE. IF SITE CONDITIONS CAUSE INSTALLATION TO DEVIATE FROM THE REQUIREMENTS DETAILED HEREIN, A LICENSED ENGINEER OR ARCHITECT SHALL PREPARE SITE SPECIFIC DOCUMENTS FOR USE WITH THIS DOCUMENT.

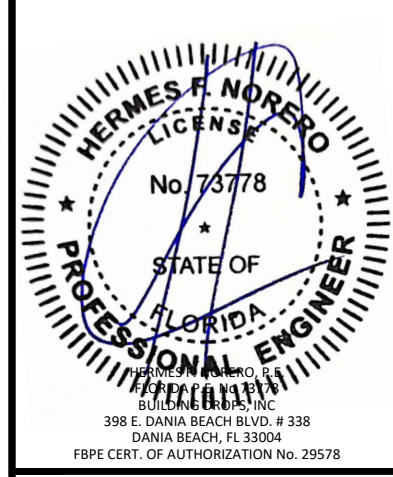

FL #: **FL41836**

DATE: **12.12.2022**

DWG. BY: **SH** | CHK. BY: **HFN**

SCALE: **NTS**

DWG. #: **DRU014**

SHEET:
8
OF 8

s:\projects\drutex, s.a\ccc-23-0959 - fbc submittal - 2023 code change\dwg\141836 - tilt & turn\dr014 - fbc 2023.dwg